



25 East State Street, North Aurora, IL 60542
 P: 630.897.1457 F: 630.897.0269
 Website: www.northaurora.org/forms/
 Email: cdinfo@northaurora.org

FENCE PERMIT APPLICATION

No fence or wall shall be erected or replaced without first obtaining a permit. Plans indicating specific locations, material, type, and height of the proposed fence shall accompany the permit application.

Job Address: _____

Is the Property Located on a Corner Lot? (choose one) Yes No

Total Cost of Project (estimated): \$ _____ **Fence Height** _____ (Feet)

Maximum Heights for Fences per Zoning District (shown in Figure 12-5)			
	<i>Front Yard and/or Corner Side Yard</i>	<i>Interior Side Yard</i>	<i>Rear Yard</i>
<i>Residential and Estate Districts</i>	Shall not exceed three feet above grade in front and four feet above grade in corner side yard.	Shall not exceed six feet above grade or eight feet above grade if adjacent to a business, office or industrial district.	Shall not exceed six feet above grade or eight feet above grade if adjacent to a business, office or industrial district.
<i>Business and Office Districts</i>	Prohibited	Shall not exceed six feet above grade or eight feet above grade if adjacent to a residential or estate district.	Shall not exceed six feet above grade or eight feet above grade if adjacent to a residential or estate district.
<i>Industrial Districts</i>	Shall not exceed eight feet above grade.	Shall not exceed eight feet above grade.	Shall not exceed eight feet above grade.

CONTACT INFORMATION:

Permit Applicant: _____ **Phone:** _____

E-Mail: _____

Property Owner: _____ **Street Address:** _____

City: _____ **State:** _____ **Zip:** _____ **Phone:** _____

E-Mail: _____

CONTRACTOR(S):

General Contractor: _____ **Office Phone:** _____

Address: _____ **City:** _____ **State:** _____ **Zip:** _____

E-Mail: _____

Please Note: The following items are required at the time of permit submittal. All required paperwork and documents must be included at the time of submittal or the submittal will not be accepted.

- **One (1) copy of the plat of survey** - illustrating with a colored pen or highlighter the exact location you would like to install the fence.
- **One (1) copy of the contract/proposal** - from the contractor performing the work.

Construction Standards:

- **Location:** A fence or wall, including all posts, bases and other structural parts shall be located completely within the boundaries of the lot on which it is located. The finished side of the fence shall face outward or away from the lot on which the fence is erected.
- **Homeowner Association:** It is the responsibility of the property owner to ensure that the proposed improvements are in accordance with all Homeowner’s Association by-laws and property covenants.
- **Vision Clearance for Driveways:** The vision clearance area at the intersection of a driveway and a property line (shown in Figure 12-2), which shall be defined as a triangular area measured fifteen (15) feet on the lot line on either side of the driveway, and shall not be obstructed by any sign, wall, fence, hedge, shrub or other object which exceeds thirty-six (36) inches in height per requirements in 12.1.G.2 of the Village’s Municipal Code.
- **Prohibited Fence Types:** No fence equipped with or having barbed wire, spikes, or any similar device, or any electrically charged fence, sufficient to cause shock shall be erected, placed and maintained in any zoning district, with the exception of agricultural and industrial uses.

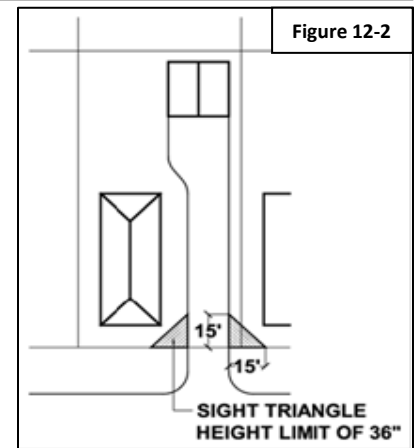
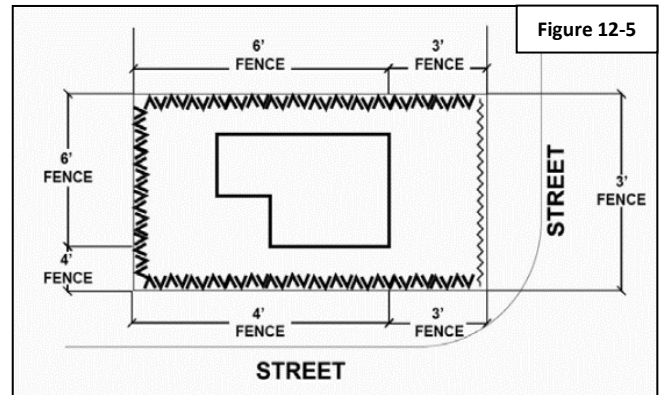

BEFORE YOU DIG - CALL J.U.L.I.E. (811)

Permit Review Time: Please allow ten (10) working days for the permit applications to be reviewed and approved. The review time does not start until all required paperwork and documents are submitted.

Permit Issuance: A staff member will notify you when your permit is ready to be picked up and paid for.

Fees: The fee for a fence permit is \$75.00. Fees are paid after a permit is approved.

Inspections: The applicant is responsible for scheduling all required inspections, which are shown on the permit job card. The permit job card must be visible from the street during construction. Should an inspection fail, a re-inspection fee may apply and must be paid prior to scheduling the re-inspection.

I hereby certify that I am the owner of record or the owner of record authorizes the proposed work, and I have been authorized to act on his/her behalf as the agent. I agree to conform to all applicable laws and ordinances of the Village of North Aurora.

Printed Name: _____

Date: _____

Signature: _____

FOR OFFICE USE

Approved by: _____

Date: _____

Total Fee: \$ _____