



## Village of North Aurora

### REQUEST FOR PROPOSAL WALK-THROUGH QUESTIONS

## Upgrade and Replace Police Facility Access Control System

Questions from walk through

1. MAP – Sent out after walkthrough Also uploaded the Village North Aurora RFP website.  
<https://northaurora.org/government/rfp-rfq-bidding/>
2. B108, B109A and B109B Card Reader Doors –
  - a. B108 NO CARD READER JAIL TO TRAP
  - b. B109A NO CARD READER BOND OUT DOOR
  - c. B109B NO CARD READER TRAP DOOR

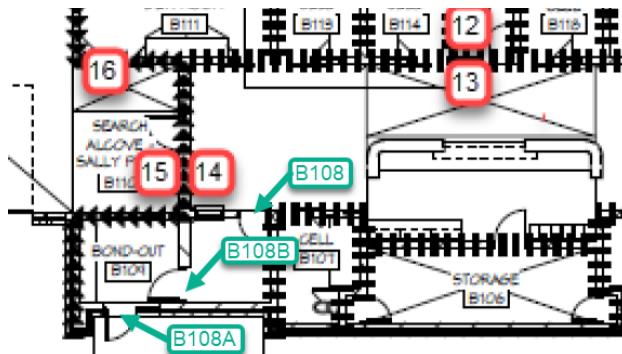

3. Printer – Current Model is Magicard Enduro 3E with duplexer.